



EST152

Electric Stacker 1.5T

- Strong chassis
- Rigid mast
- Easy operation
- Efficient hydraulic system

iMOW
www.imowshop.com



Scan and Enter iMOW Website



iMOW

NO.121 Yonghua Street, Shiqiao Road, Xia Cheng Qu, Hangzhou, China 86-571-28035665

86-571-28035656/28878695

www.imowshop.com

info@imowshop.com

PRODUCT FEATURES

■ Strong chassis

The side impact beam, plates, and boxes make the chassis stronger and can greatly reduce stress and deformation caused by heavy load.

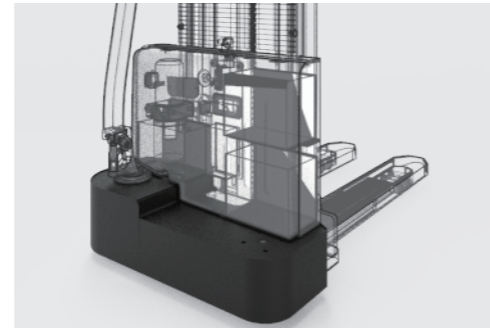

■ Rigid mast

The rigidity of the mast is greatly improved by its beam structure to provide smooth lifting and stacking for daily operation.

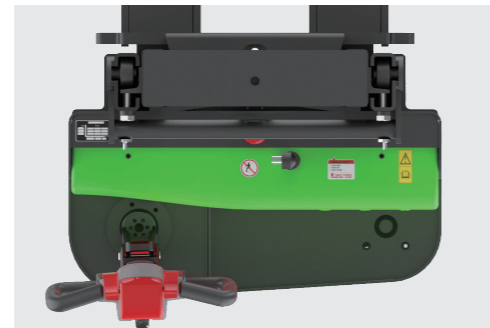

■ Easy operation

The extra-long and offset tiller with the crawl speed button provides EST152 a better visibility and nimble maneuverability when operating in tight space.

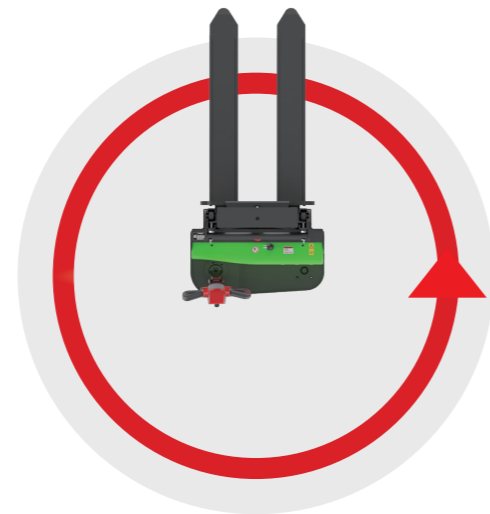

■ Efficient hydraulic system

High quality hydraulic pump ensures very little noise, maximum efficiency, durability and shortens lifting time.

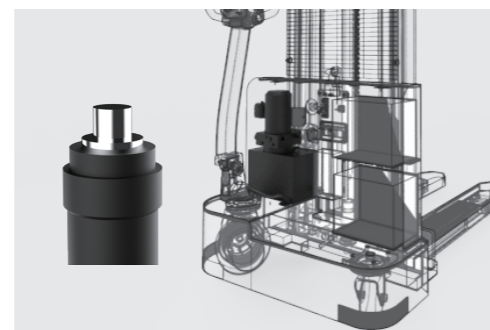

PRODUCT PARAMETERS

Distinguishing mark			
1.1	Manufacturer		iMOW
1.2	Model designation		EST152
1.3	Drive unit		electrics
1.4	Operator type		pedestrian
1.5	rated capacity	Q	t
1.6	Load center distance	c	mm
1.8	Load distance, centre of drive axle to fork	x	mm
1.9	Wheelbase	y	mm
Weight			
2.1	Service weight (include battery)		kg
2.2	Axle loading, laden driving side/loading side		kg
2.3	Axle loading, unladen driving side/loading side		kg
Types, Chassis			
3.1	Tyre type Driving wheels/Loading wheels		PU/PU
3.2	Tyre size, driving wheels (diameter×width)		mm
3.3	Tyre size, loading wheels (diameter×width)		mm
3.4	Tyre size, caster wheels (diameter×width)		mm
3.5	Wheels, number driving, caster/loading (x=drive wheels)		mm
3.6	Track width, front, driving side	b10	mm
3.7	Track width, rear, loading side	b11	mm
Dimensions			
4.2	Height, mast lowered	h1	mm
4.4	Lift height	h3	mm
4.5	Height, mast extended	h4	mm
4.9	Height drawbar in driving position min./max.	h14	mm
4.15	Lowered height	h13	mm
4.19	Overall length	l1	mm
4.2	Length to face of forks	l2	mm
4.21	Overall width	b1	mm
4.22	Fork dimensions	s/ e/ l	mm
4.24	Fork carriage width	b3	mm
4.25	Distance between fork-arms	b5	mm
4.32	Ground clearance, center of wheelbase	m2	mm
4.34.1	Aisle width for pallets 1000 × 1200 crossways	Ast	mm
4.34.2	Aisle width for pallets 800 × 1200 lengthways	Ast	mm
4.35	Turning radius	Wa	mm
Performance data			
5.1	Travel speed, laden/ unladen		km/ h
5.2	Lifting speed, laden/ unladen		m/ s
5.3	Lowering speed, laden/ unladen		m/ s
5.8	Max. gradeability, laden/unladen		%
5.10	Service brake type		
Electric-engine			
6.1	Drive motor rating S2 60 min		kW
6.2	Lift motor rating at S3 15%		kW
6.3	The maximum allowed size battery		mm
6.4	Battery voltage/nominal capacity K20		V/ Ah
6.5	Battery weight		kg
Addition data			
8.1	Type of drive unit		
10.5	Steering type		
10.7	Sound pressure level at the driver's ear		dB (A)

LINE GRAPH

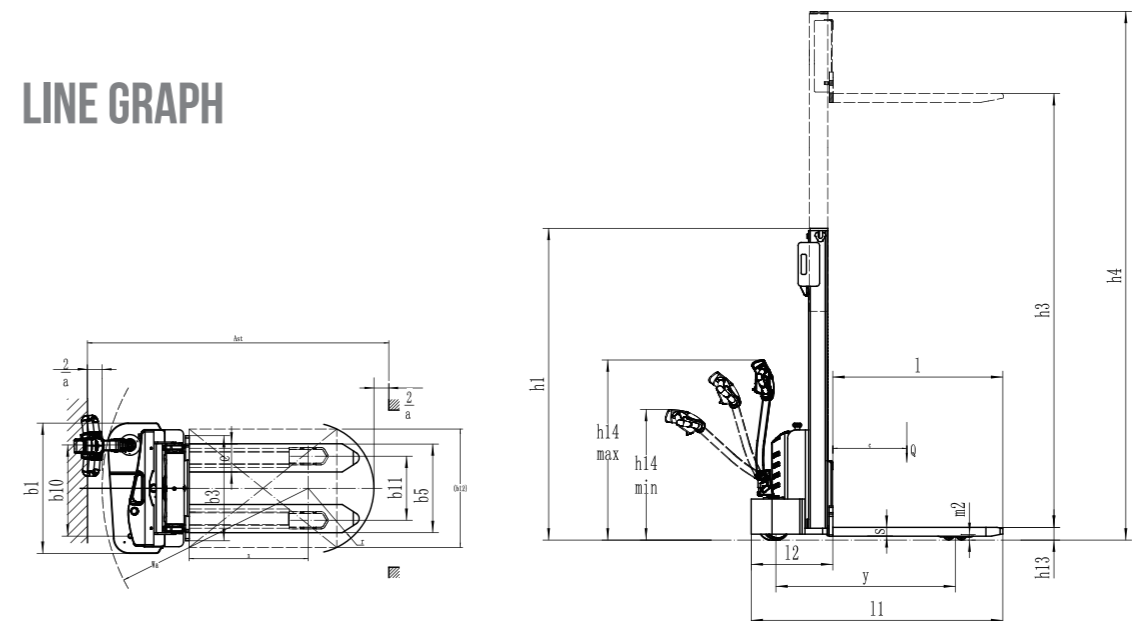

MAST OPTION

Mast types	Lift	h3+h13	Lowered mast height	h1	Free lift	h2	Extended mast height	h4
Duplex ZT		2520		1856		—		3071
		2720		1956		—		3271
		3020		2106		—		3571
		3320		2256		—		3871

RATED CAPACITY

RATED CAPACITIES GRAPH

